

DETAIL A
E1

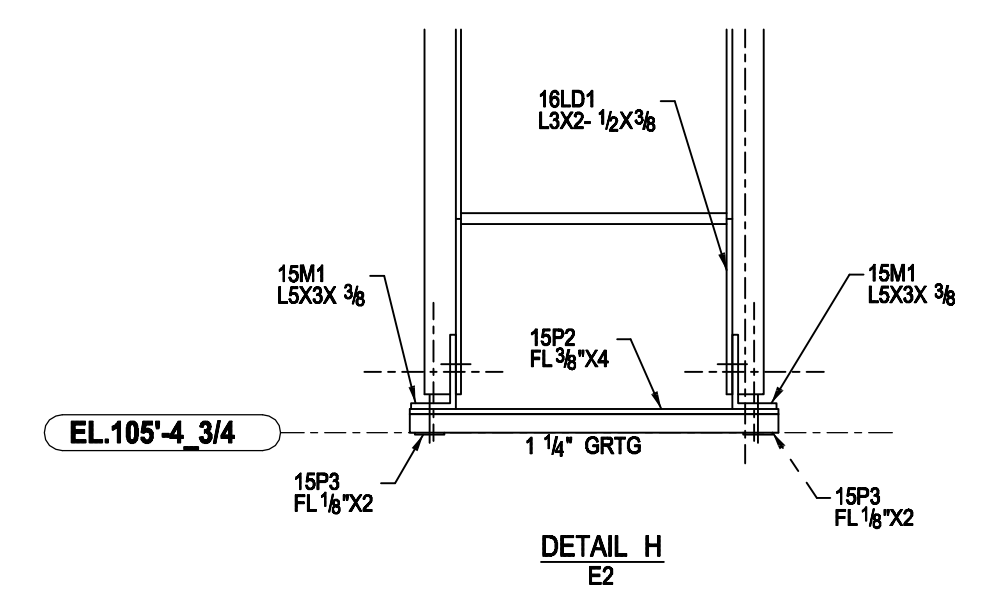
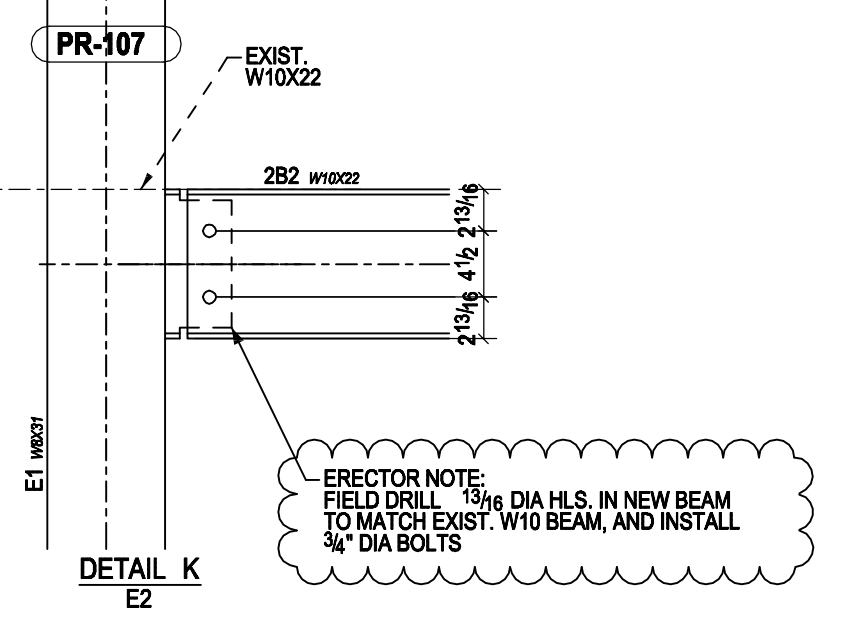
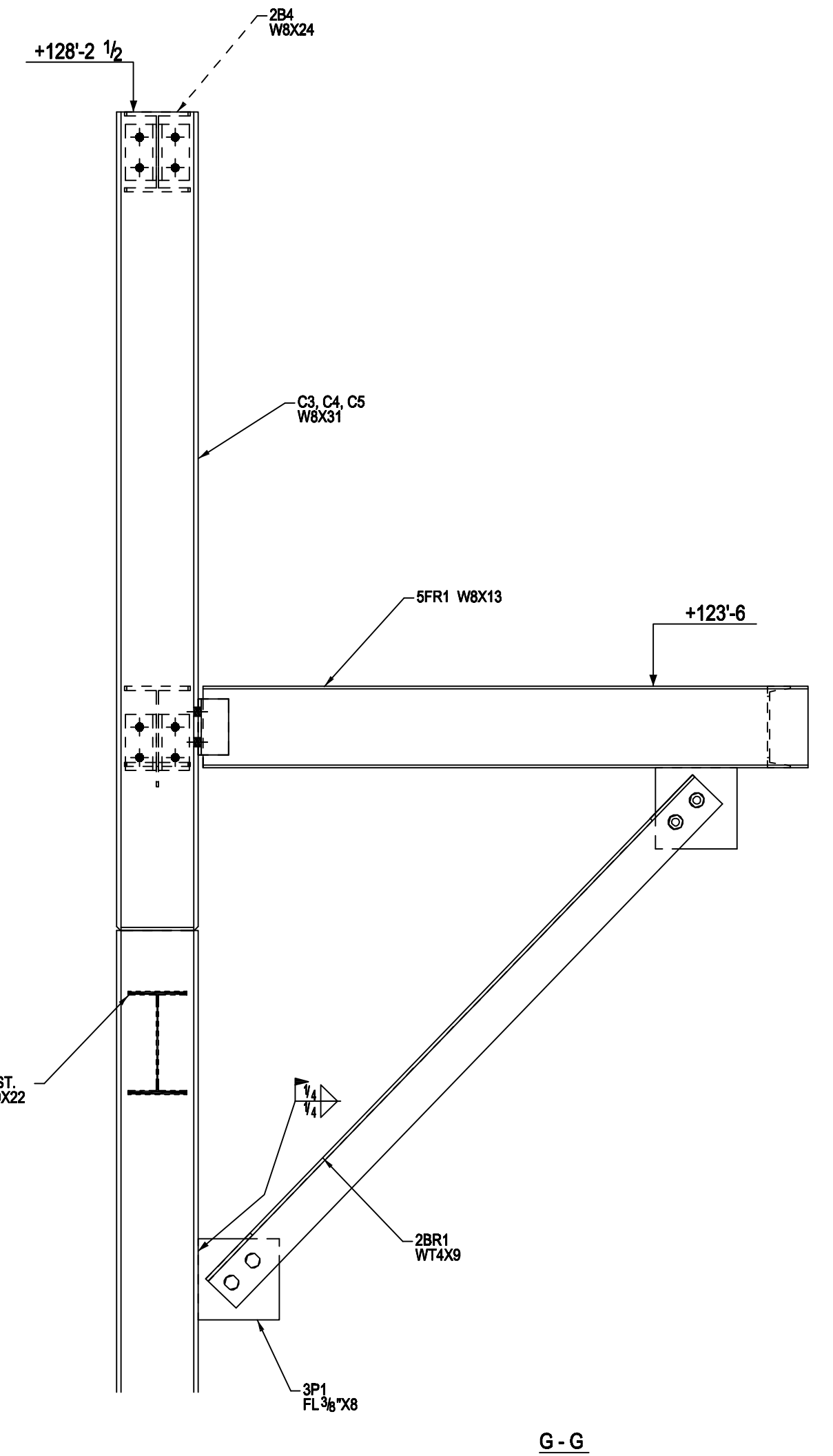
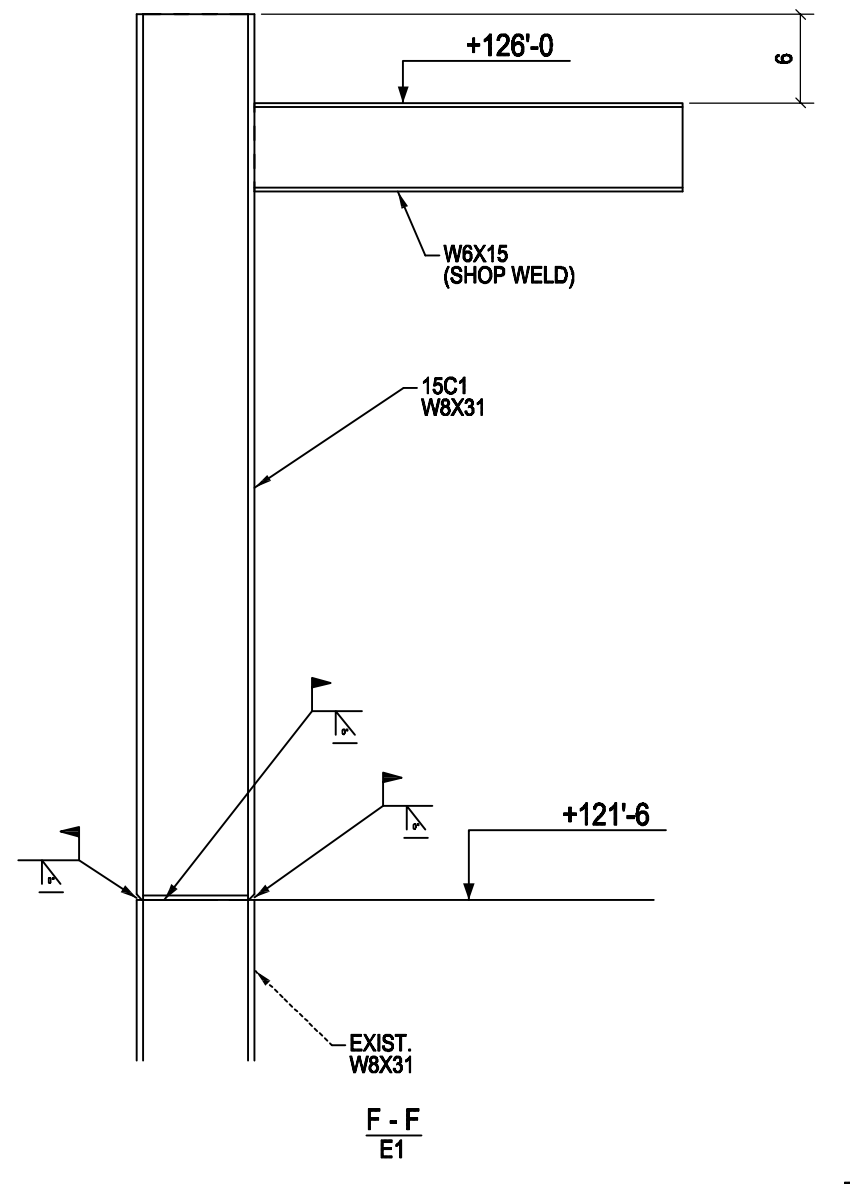
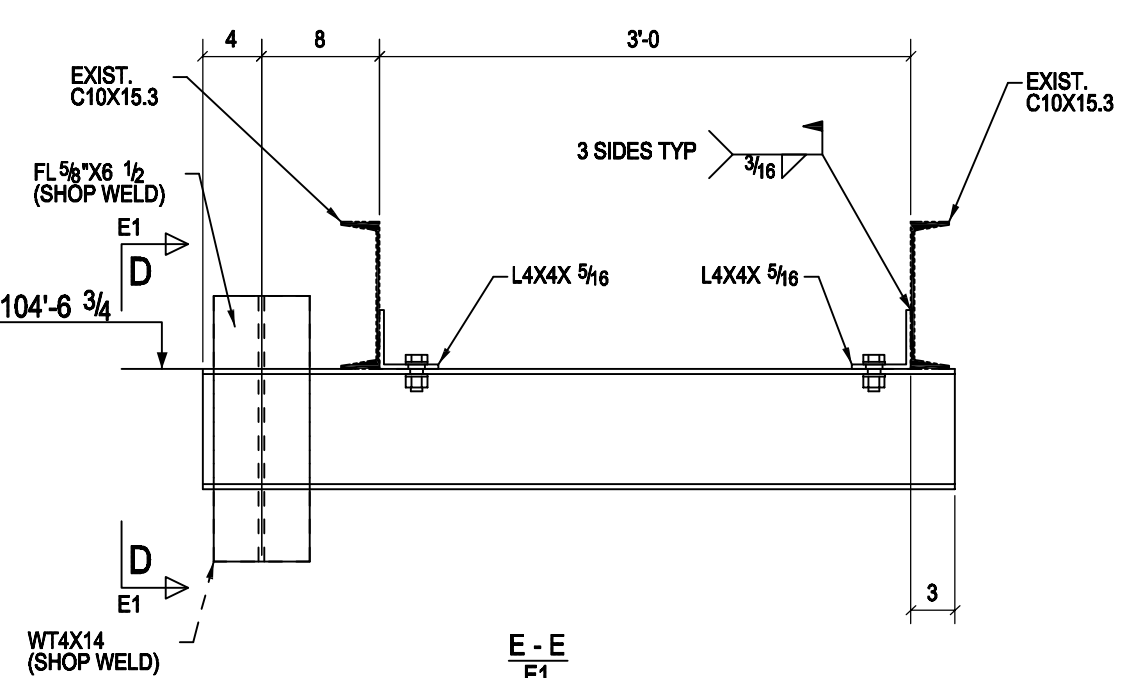
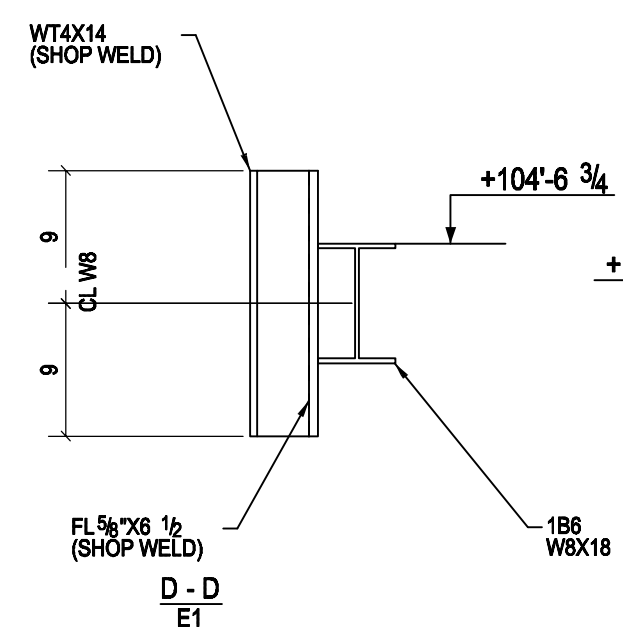
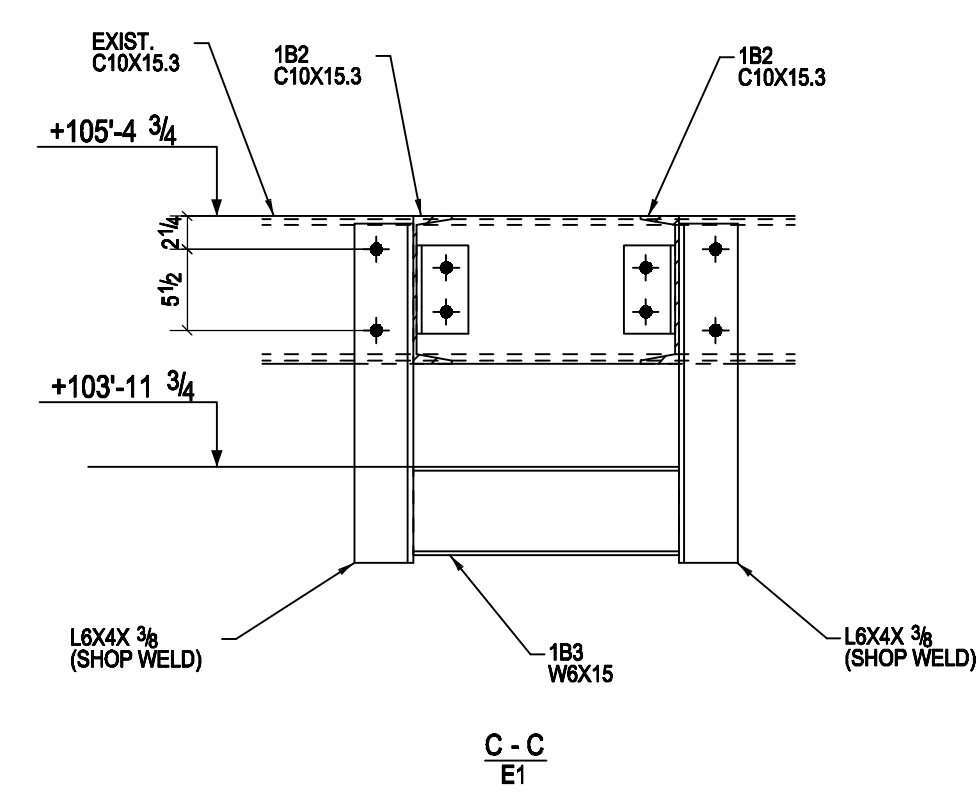

STEEL IS HOT DIPPED GALV.
SHOP DRILL VENT HOLES
AS REQUIRED.
SEAL WELD ALL JOINTS

| | | | |
|------------|---------------|-------------------|--|
| HOLES | 7/8" Ø U/N | MATERIAL: | W.W.T. : ASTM A992 C's L's PLTS: ASTM A36 TUBES: A500 GR. B PIPE: A53 GR. B |
| PAINT | GALVANIZED | ERECTOR DWG. REF. | N/A |
| WELDING | PER AWS D.1.1 | CUST. DWG. REF. | 58MS8520-S-CS-S-SK-007 |
| ELECTRODES | E70XX | SCALE | 1"=1'-0" |

| | | | |
|-------------------------|-------------|----|------|
| ISSUED FOR CONSTRUCTION | | | |
| ISSUED FOR APPROVAL | | | |
| REV | DESCRIPTION | BY | DATE |

| | | | | |
|----------|--------------------|---------|----------|-----------|
| CUSTOMER | | | | |
| CONTRACT | | | | |
| LOCATION | | | | |
| TITLE | SECTIONS & DETAILS | | | |
| DRN | DATE | JOB NO. | DRG. NO. | REV. |
| CHKD | DATE | | | E3 |