

### BILL OF MATERIAL

MARK	QTY	DESCRIPTION	LENGTH	WEIGHT	REMARKS
16LD1	1	CAGED_LADDER			SQ-2
16LD1	1	L3X2-1/2X3/8	23'-1 7/8"	151	A36
p16	2	FL1/4X3"	1'-0 1/8"	11	A36
p32	1	FL1/4X3"	0'-3 1/2"	1	A36
p33	2	FL1/4X1 1/2"	14'-1 7/8"	36	A36
p34	3	FL1/4X1 1/2"	14'-11 1/8"	57	A36
p35	1	FL1/4X3"	9'-7 3/4"	12	A36
p36	3	FL1/4X2"	7'-7 1/4"	39	A36
p37	1	FL1/4X3"	9'-3 13/16"	24	A36
p38	1	L3X2-1/2X3/8	23'-1 7/8"	151	A36
p41	2	FL1/4X1 1/2"	18'-11 1/8"	48	A36
r1	23	ROD3/4"	1'-6 1/2"	48	A36
TOTAL WEIGHT THIS DRAWING				579	

SHOP NOTE:  
BOUGHT ITEM: INTREPID SAFETY GATE MODEL DG  
ONE REQUIRED

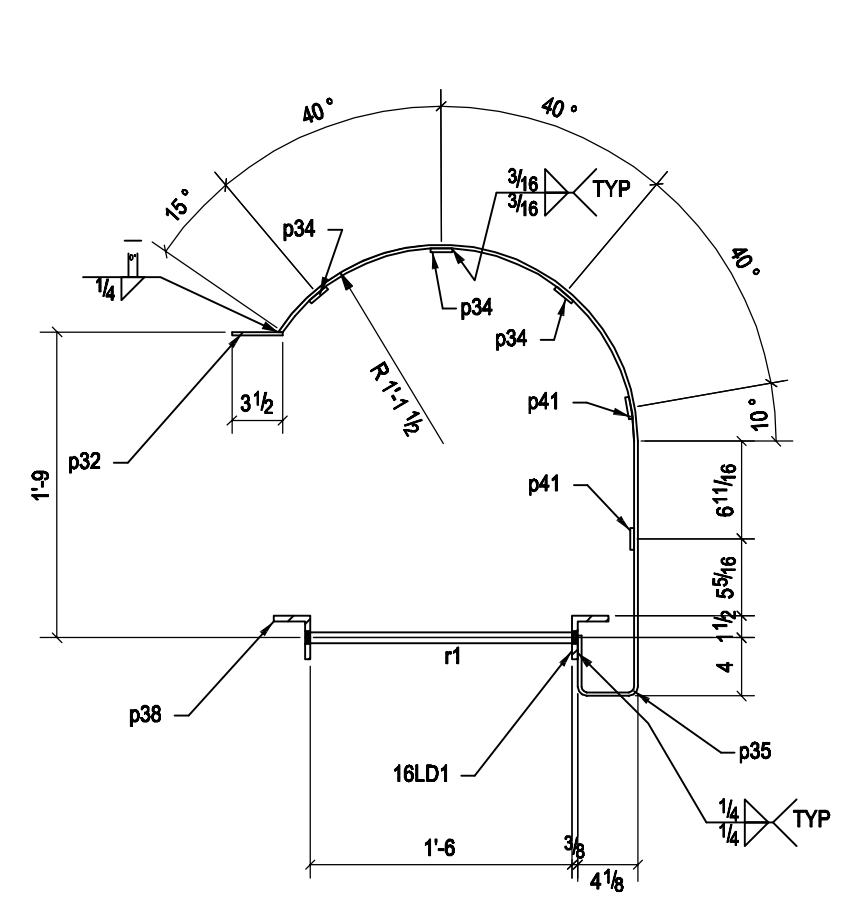
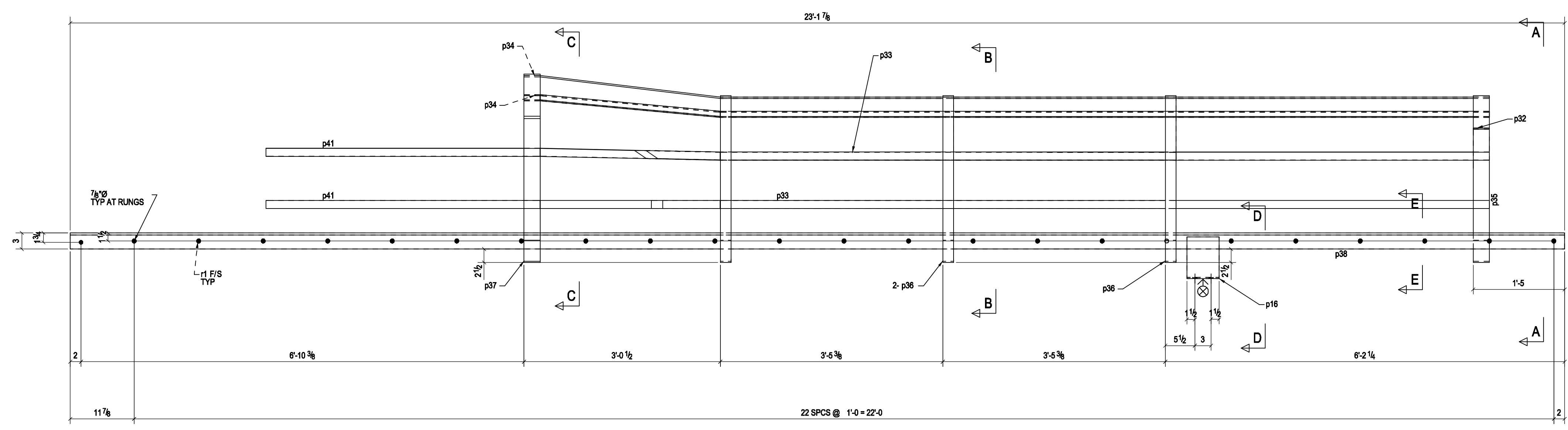

A - A

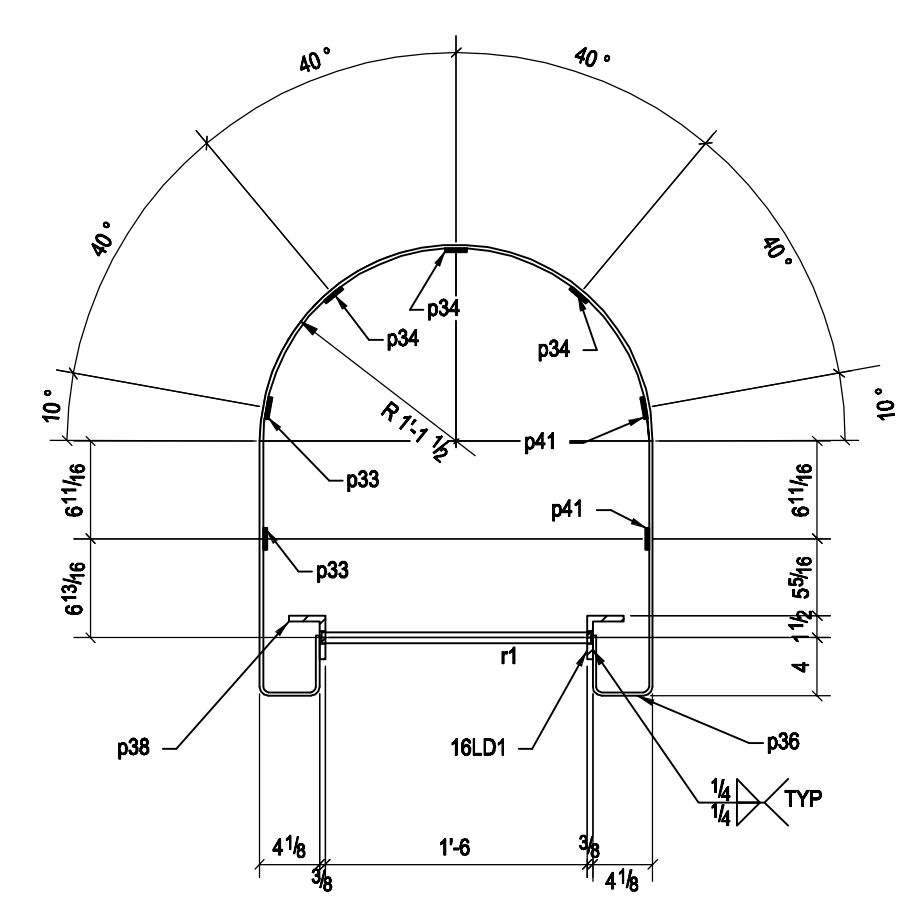

B - B

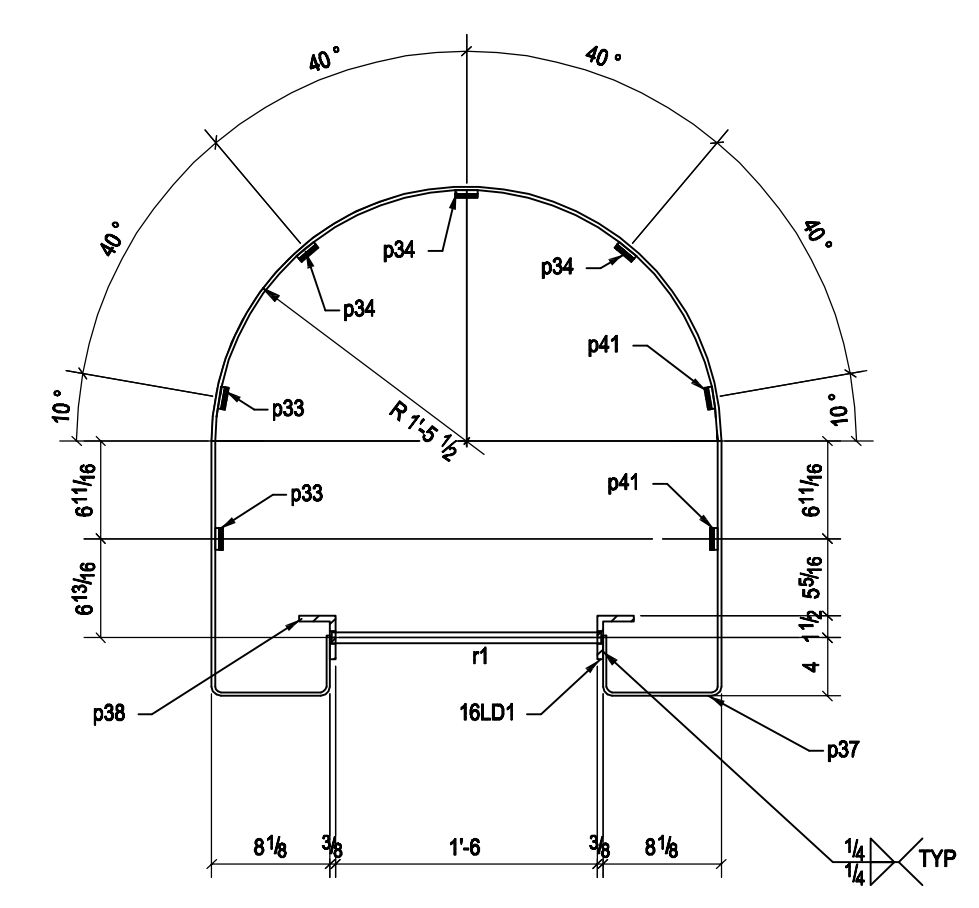

C - C  
1 - CAGED LADDER - 16LD1

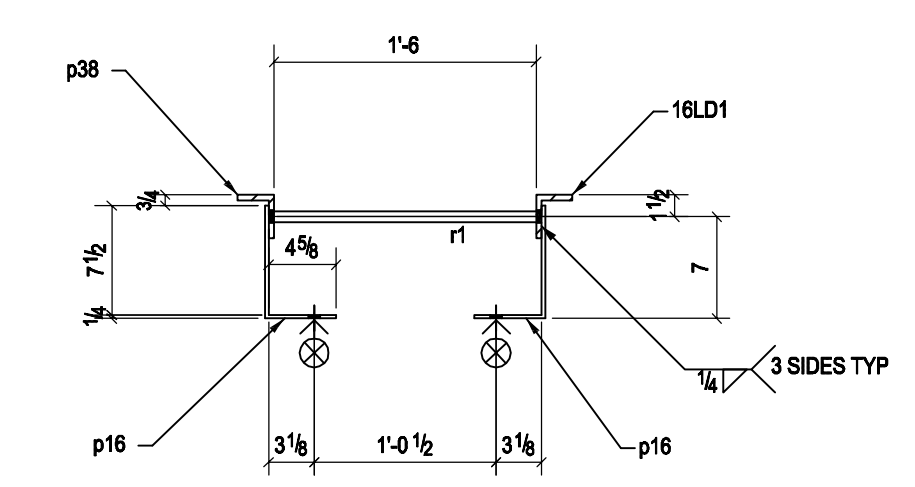

D - D

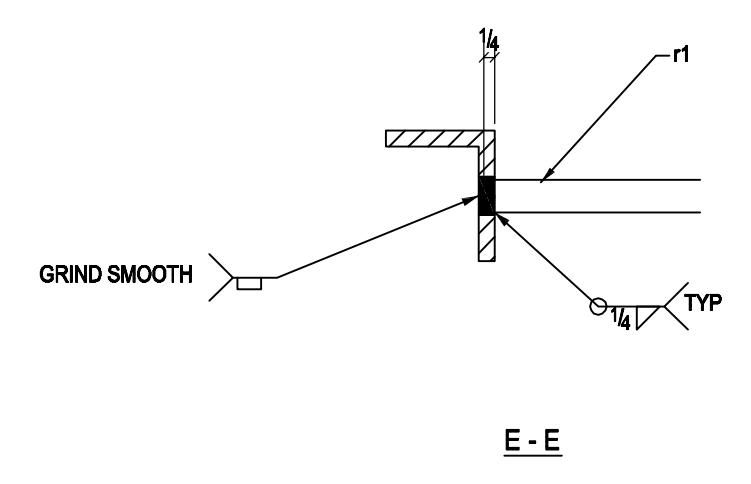

E - E

STEEL IS HOT DIPPED GALV.  
SHOP DRILL VENT HOLES  
AS REQUIRED.  
SEAL WELD ALL JOINTS

△					
△	ISSUED FOR CONSTRUCTION				
△	ISSUED FOR APPROVAL				
REV	DESCRIPTION	BY	DATE	CHKD	DATE

CUSTOMER			
CONTRACT			
LOCATION			
TITLE	LADDER		
DRN	DATE	APP. NO.	REV.
CHKD	DATE		16